

3d video

Past, Present, Future

Information Coding Group
Linköpings universitet

Motivation

- James Camerons Avatar – first Hollywood fulllength feature film to be filmed and produced completely in both 2D and 3D
 - But not first 3D movie in recent years!
 - Movies tailored to 3D (documentations e.g. Deep Sea, concerts e.g. U2 3D)
 - Feature films containing 3D scenes (e.g. Harry Potter and the Half-Blood Prince)
 - Animation movies (e.g. Pixar's Up); older 2D animation movies are planned to be rereleased in 3D
- 3D version of a movie generally more popular than its 2D counterpart
- Part of ongoing trend towards 3D

Why now?

- Price aspects
 - 3D systems became only recently cheap enough for broad usage
 - and common enough to be interesting for content producers
- Quality aspects

Bringing 3D home

- But still a lot to do to introduce 3D to private homes
- Cinema systems not applicable to living rooms
- Different usage scenario:
 - Living room is no cinema!
 - Event vs everyday life
 - Comfort much more important
 - Used as “background activity”

Outline

Quality and usage aspects

3D display system overview

3D video coding and rendering

Quality and usage aspects

- Motion parallax:
 - The change of the perspective in accordance to the occurring movement
 - Can be introduced e.g. by using eye-tracking
 - Most only consider horizontal motion parallax, what about vertical?
- Eye fatigue:
 - General fatigue, headache, pain in or around eyes, blurred or double-vision
 - Different causes:
 - Crosstalk
 - Flickering image
 - Cannot focus correctly

Quality and usage aspects

- Other effects:
 - Keystone Distortion
 - Wrong parallax due to incorrectly matched views
 - Puppet Theater Effect
 - Size and distance of an observed object don't seem to match
 - Cardboard Effect
 - Perceived depth too small for perceived size
 - Stereo-Inversion
 - Left eye receives right image and vice versa
 - Picket-fence Effect
 - Moiré effect caused by interference of the screen raster and the 3D filter

Quality and usage aspects

- Reducing of depth can reduce crosstalk and eye strain, but may not be visible
- Generally: artifacts and distortion less visible as in 2D, except for disparities and blockiness which have a greater impact on the subjective quality and can cause eye strain!

Quality and usage aspects

- Asymmetric coding: the higher quality signal blocks out artifacts and distortion the from the lower quality signal

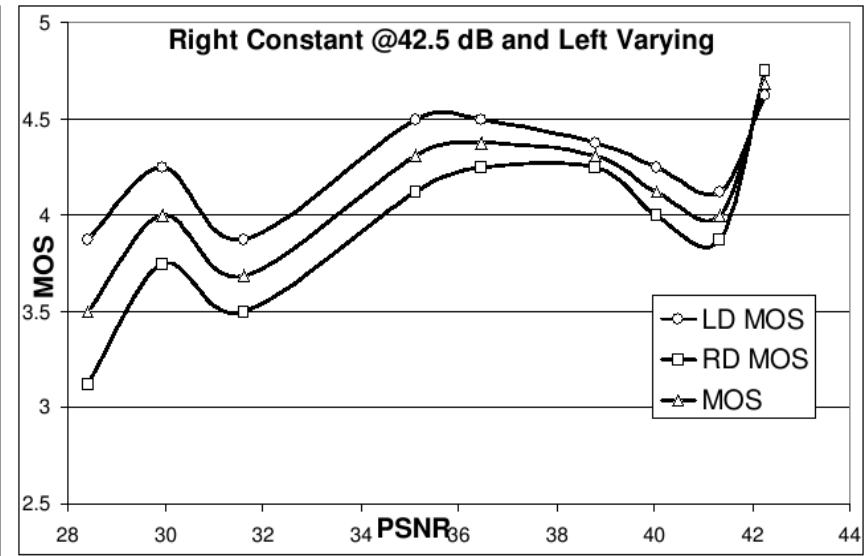
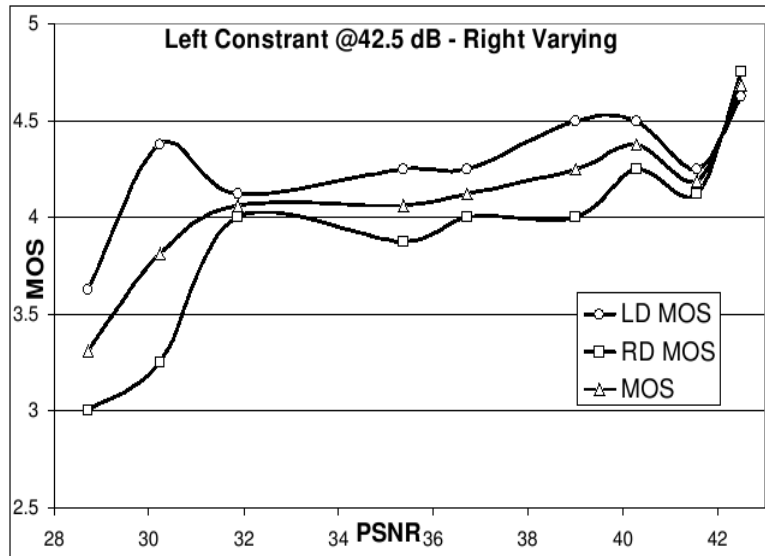

Quality and usage aspects

- Usage aspects
 - Action movies, live events, sports & concerts
 - Depth impression and switch between 2D/3D key features
 - Main reason is to be entertained, experience of 3D itself less important
 - 3D leads to a higher immersion than 2D => less used as background activity?

Display techniques: Stereoscopic

- Presenting a different image to each eye
- Side-by-side method



Display techniques: Stereoscopic

- Presenting a different image to each eye
- Side-by-side method (since 1840)



Display techniques: Stereoscopic

- Presenting a different image to each eye
- Side-by-side method (since 1840)
- Modern variant: VR systems



Display techniques: Stereoscopic (glasses)

- Anaglyph method

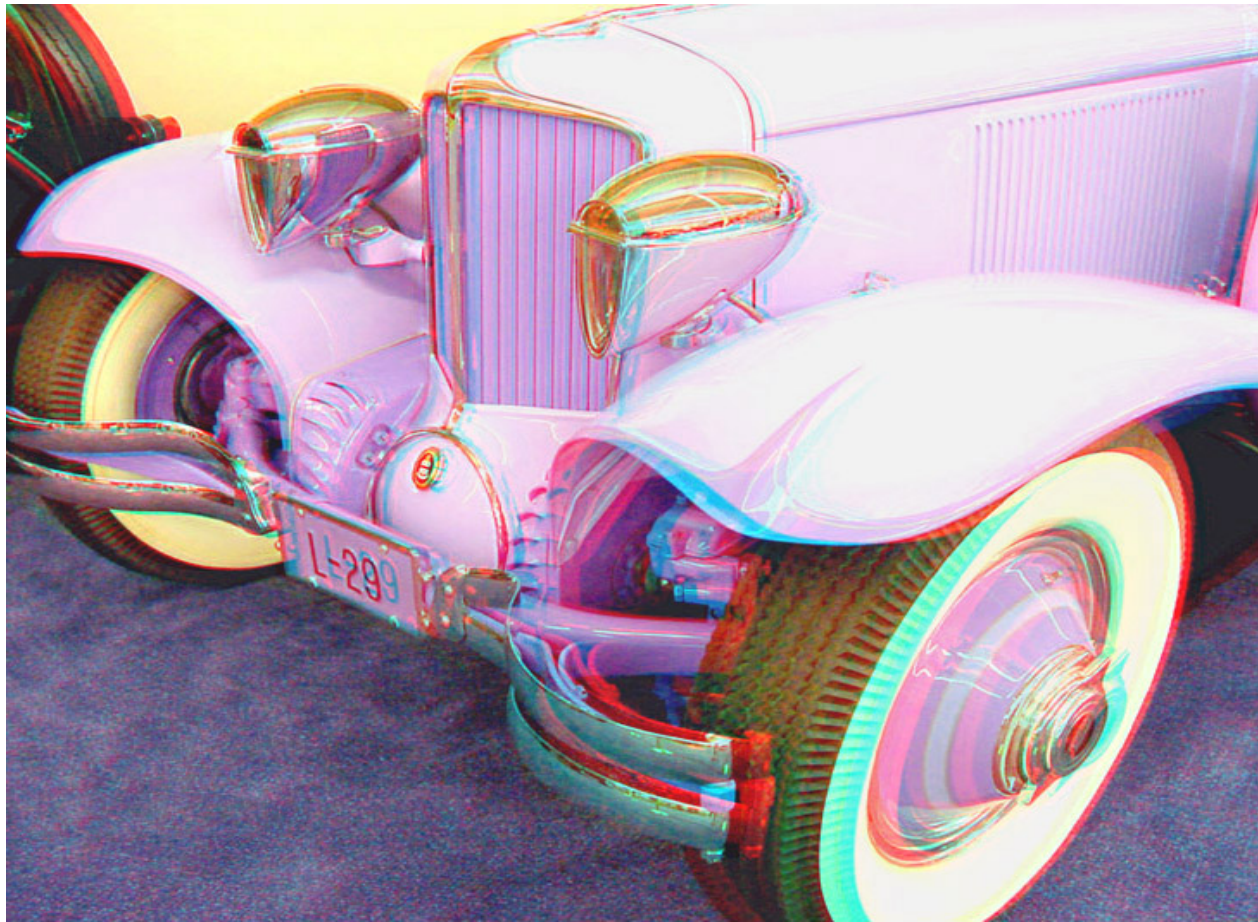

Display techniques: Stereoscopic (glasses)

- Anaglyph method
- “color multiplexing”
 - limited colorspace
 - highly susceptible to crosstalk
 - + glasses very cheap
 - + directly compatible to existing systems

Display techniques: Stereoscopic (glasses)

- Shutter glasses: time multiplex
- Needs synchronization with displaying system
- Need to introduce guardbands to avoid crosstalk
- Used in Nvidias 3D initiative



Display techniques: Stereoscopic (glasses)

- Shutter glasses: time multiplex
- Needs synchronization with displaying system
- Need to introduce guardbands to avoid crosstalk
- and in Segas Master System back in the 80s



Display techniques: Stereoscopic (glasses)

- Shutter glasses: time multiplex
 - Needs synchronization with displaying system
 - Need to introduce guardbands to avoid crosstalk
 - susceptible to crosstalk even with guardbands due to bad synchronization and after-images
 - expensive glasses due to synchronization logic, glasses battery powered
 - due to “black period” for each eye: flicker (if framerate is too low) and subjective brightness reduction possible
- + partly compatible to existing solutions

Display techniques: Stereoscopic (glasses)

- Polarization multiplex
- 1952: first 3D cinema movie in color



Display techniques: Stereoscopic (glasses)

- Polarization multiplex
- 1952: first 3D cinema movie in color
- Stilled used in IMAX 3D today, but:
- nowadays circular polarization used (to remove crosstalk)
 - reduces brightness by approx. half (depending on projector)
 - needs special, expensive screens (silver or aluminum alloy) (not suited for living rooms)

Display techniques: Stereoscopic (glasses)

- For own experiments:

Using cellophane to convert a liquid crystal display screen into a three dimensional display (3D laptop computer and 3D camera phone)

Display techniques: Stereoscopic (displays)

- Autostereoscopic displays
- Parallax barrier vs lenticular sheet

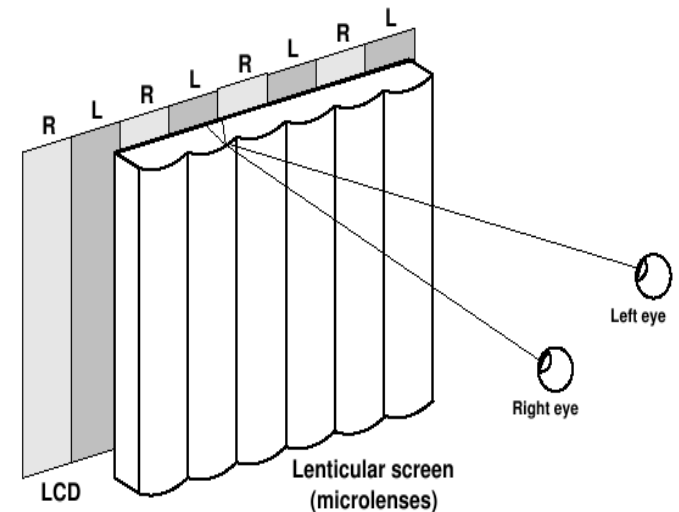
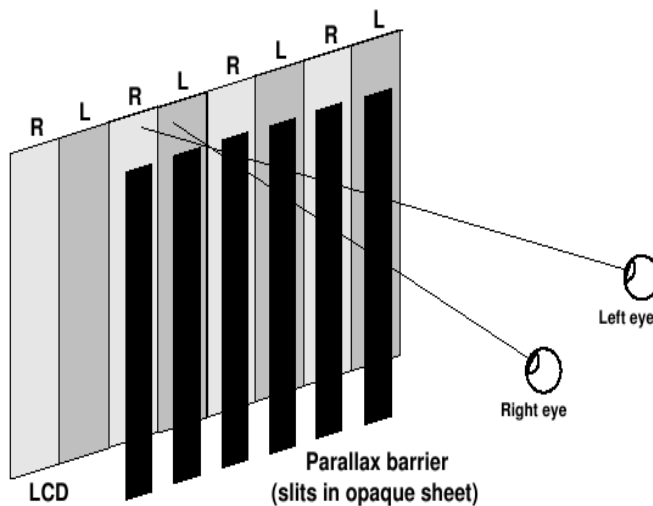

Display techniques: Stereoscopic (displays)

- Autostereoscopic displays
- Parallax barrier vs lenticular sheet
 - Parallax barrier simpler switch between 2D and 3D
 - Lenticular sheet less brightness loss
 - and bigger viewing window
- Brightness vs crosstalk
 - reduces resolution & brightness
 - susceptible to picket-fence effect
 - only one viewer possible, which needs to sit still in one position

Display techniques: Stereoscopic (displays)

- Autostereoscopic displays with eye-tracking
- Move parallax barrier / lenticular sheet or LEDs / projector according to head movement
- Could also be used to introduce motion parallax (in reality however seldom done)
 - reduces resolution & brightness
 - still only one viewer
 - + full motion parallax possible

Display techniques: Stereoscopic (displays)

- Autostereoscopic multiview displays
- Project several (e.g. 4, 5, 7 or 8) different views

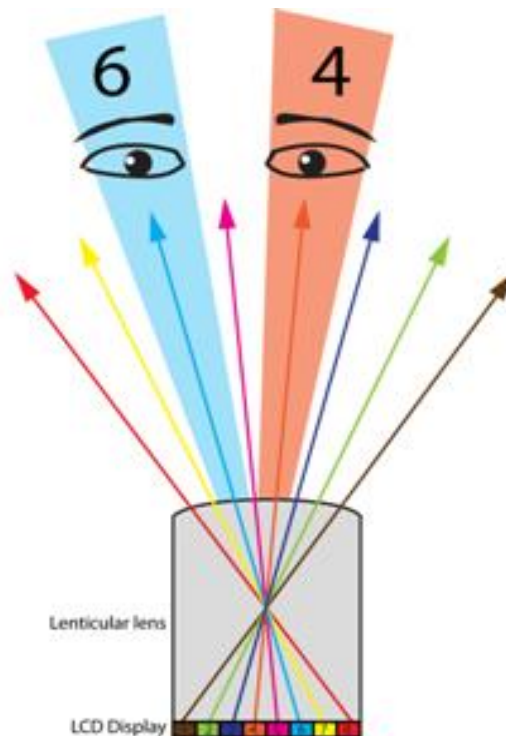

Display techniques: Stereoscopic (displays)

- Autostereoscopic multiview displays
- Project several (e.g. 4, 5, 7 or 8) different views
- Easier to introduce using lenticular sheets
- Guard band needed to avoid stereo inversion
- Brightness vs crosstalk vs number of views
- Number of views vs resolution
- Already in usage for 3D-CAD, medical appliances but mainly advertisement

Display techniques: Stereoscopic (displays)

- Autostereoscopic multiview displays
 - Project several (e.g. 4, 5, 7 or 8) different views
 - reduces significantly resolution and brightness as well
 - susceptible to picket-fence effect
- + partly motion parallax possible

Display techniques: Stereoscopic (displays)

- Autostereoscopic displays with super multiview
- Parallax interval needs to be less than diameter of the pupils of the viewer (ca. 3 to 8 mm)
- Volumetric display?
 - high number of views needed => needs very high DPI, reduces heavily resolution
 - artifacts?
 - + fully motion parallax

Display techniques: Volumetric displays

- Swept volume displays:
 - Voxel vs pixel
 - Susceptible to flicker
 - Occlusion hard, if not impossible to introduce

Display techniques: Volumetric displays

- Swept volume displays: projector + mirror

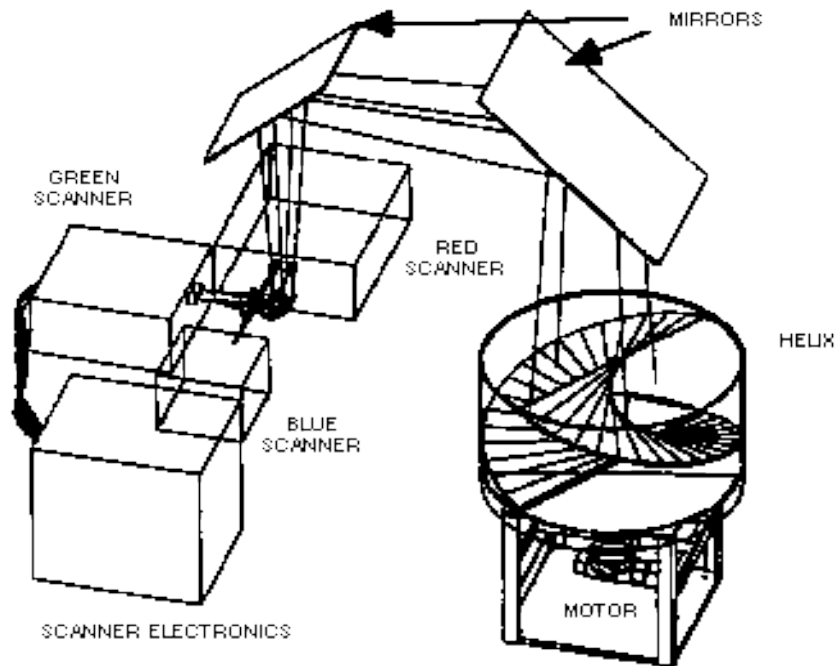

Display techniques: Volumetric displays

- Swept volume displays: moving display

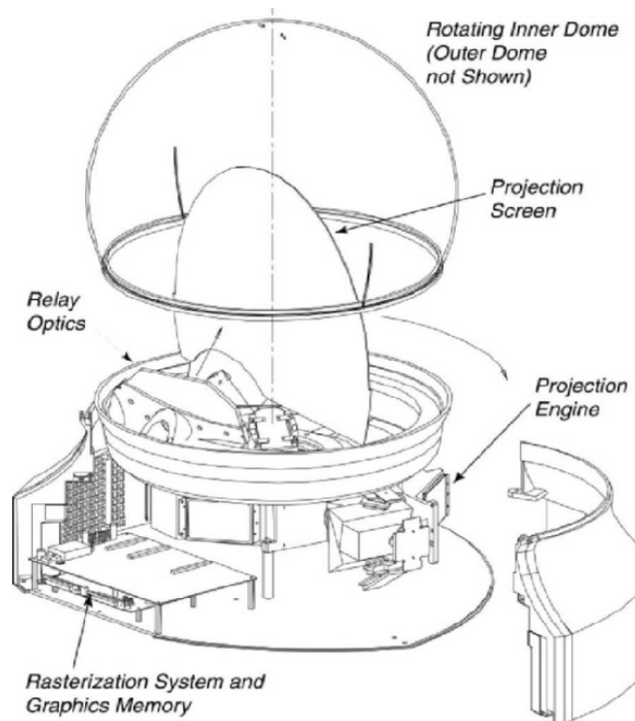

Display techniques: Volumetric displays

- Swept volume displays: static display

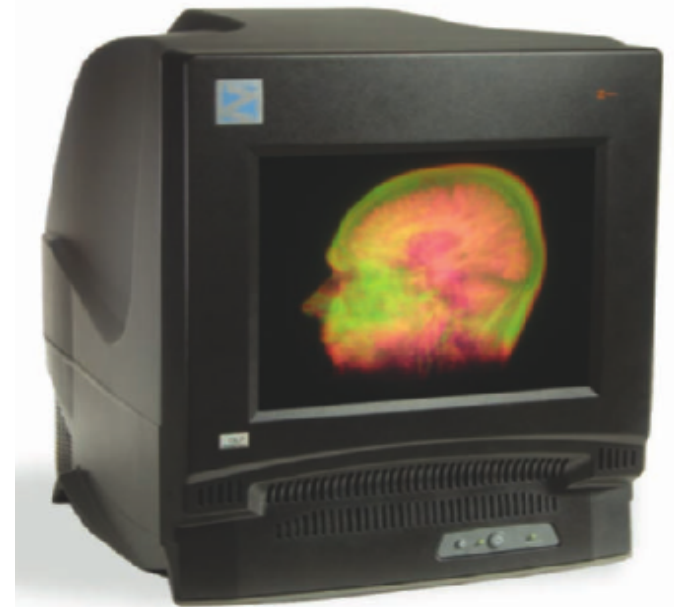
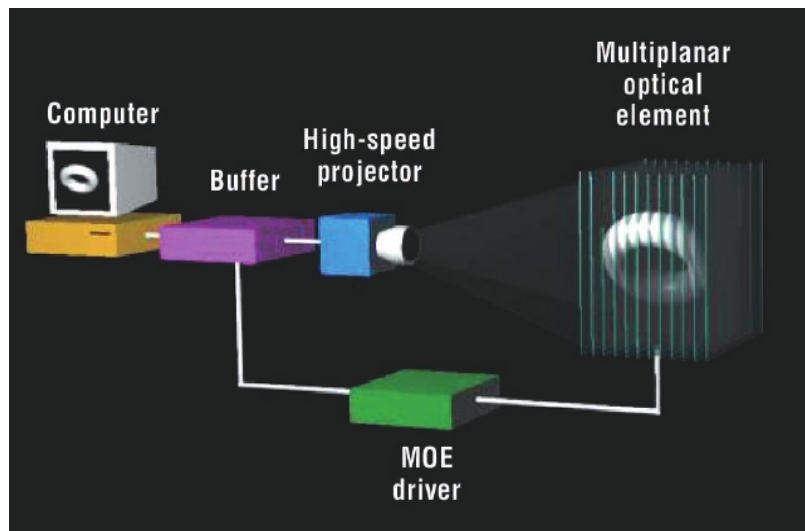

- cardboard effect vs depth resolution

Display techniques: Volumetric displays

- Swept volume displays: static display
- Laser writing image
- Known since early 70s

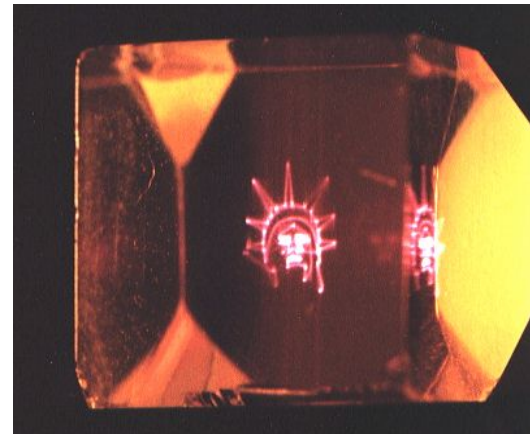
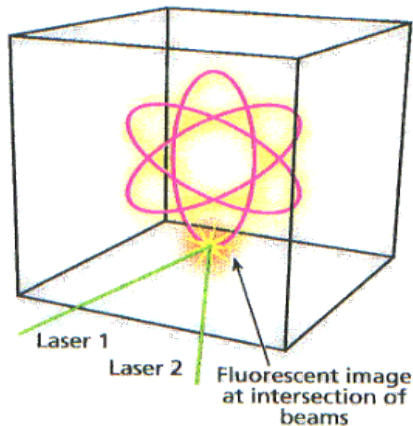

Display techniques: Volumetric displays

- Swept volume displays: static display
- Laser writing image
- Known since early 70s

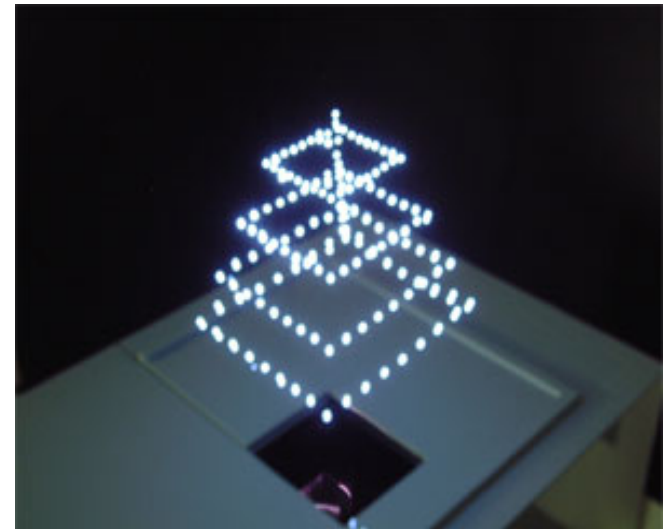
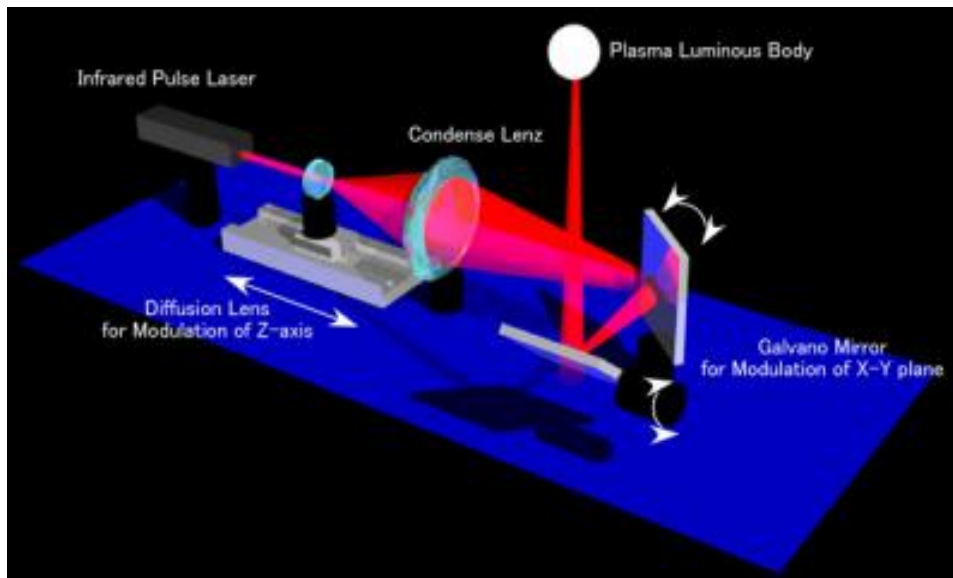

Display techniques: Volumetric displays

- Electroholographic displays

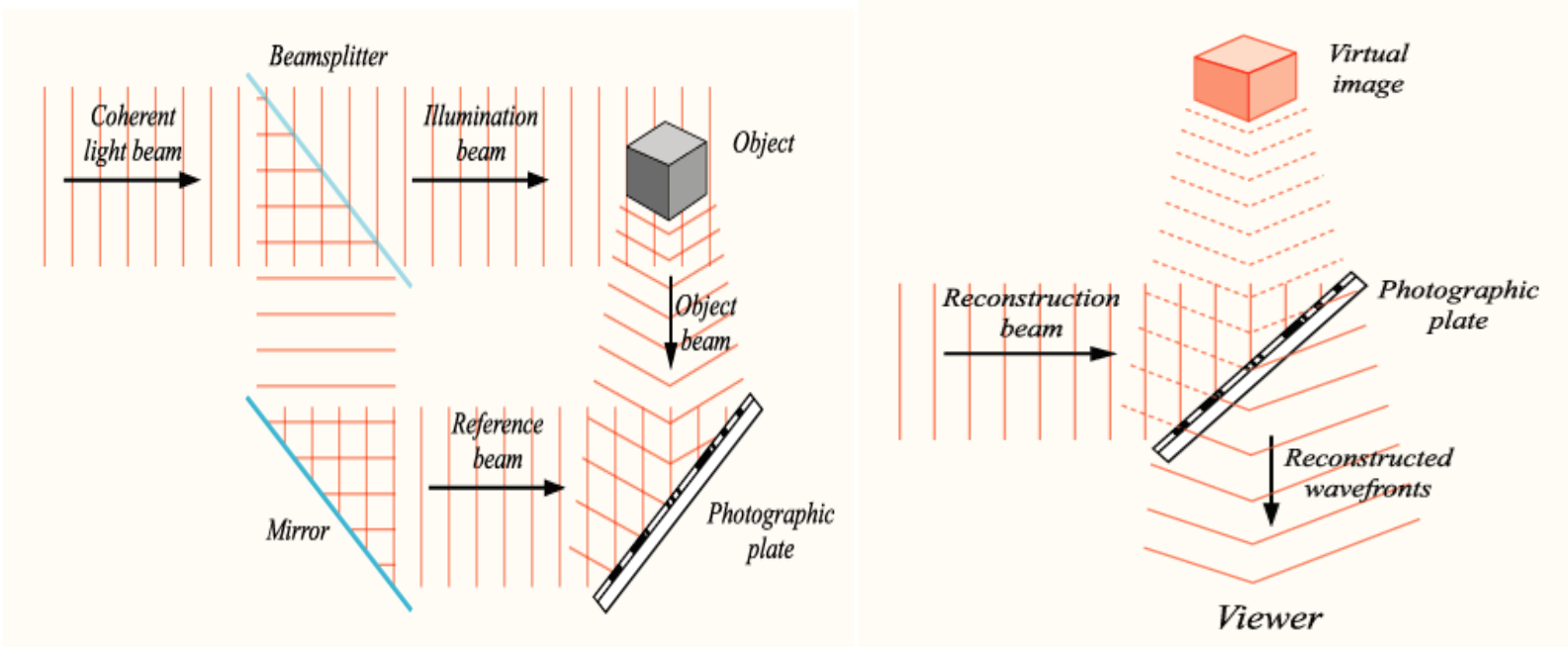

- Safes not only wavelength, but also angle and phase

Display techniques: Volumetric displays

- Electroholographic displays

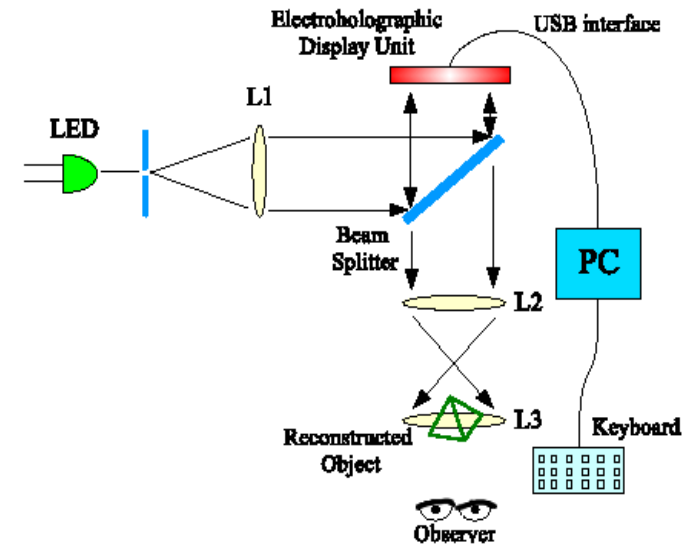
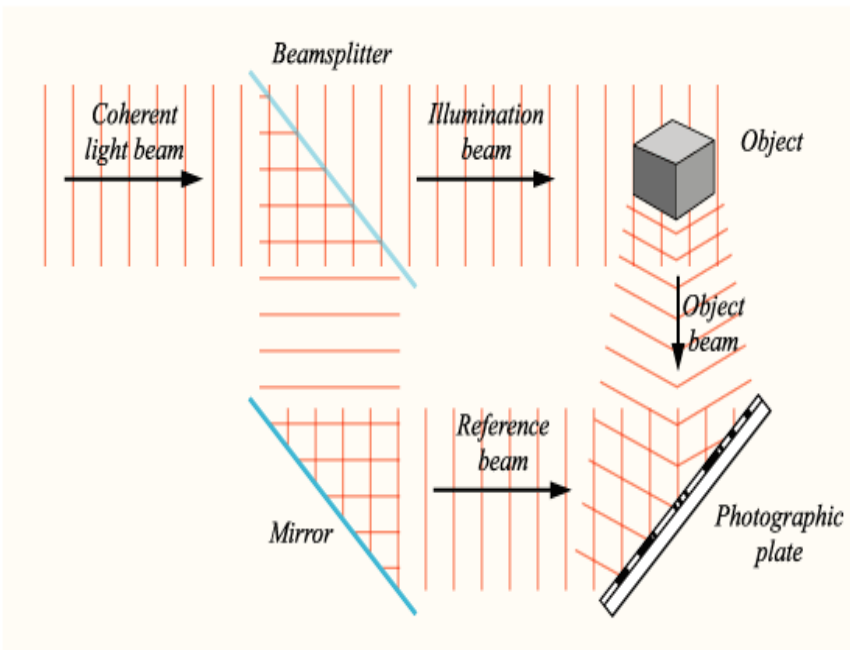

- Safes not only wavelength, but also angle and phase

Display techniques: Volumetric displays

- Holographic displays

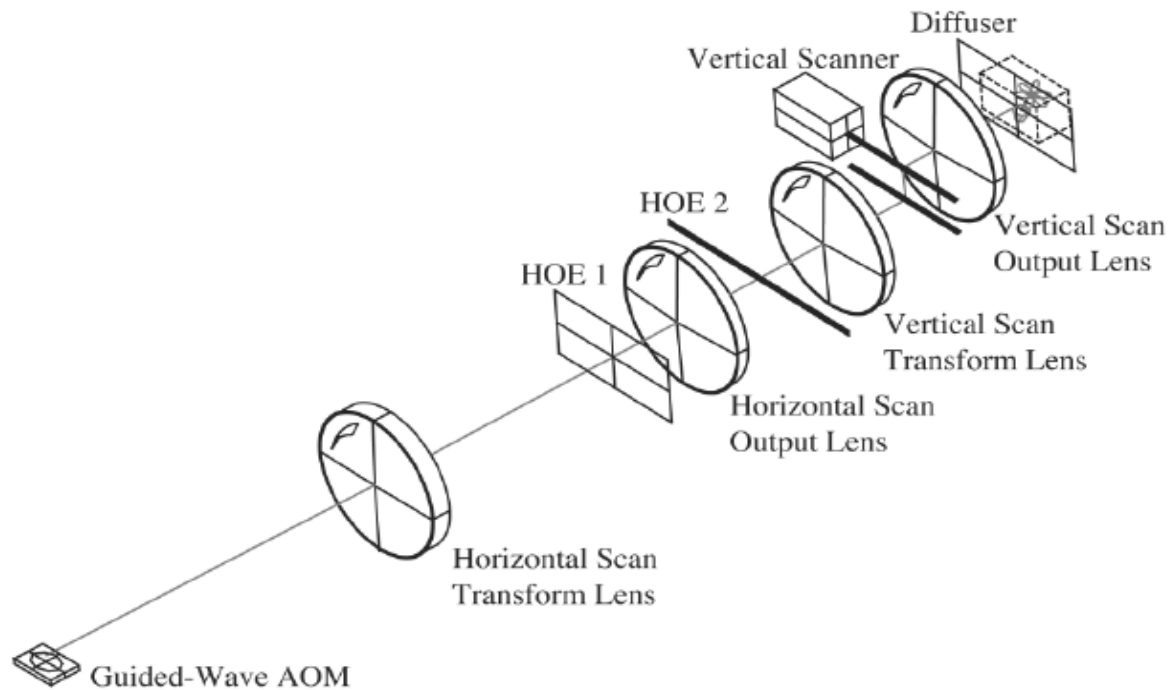

- Use acousto-optic modulator: diffracts light, steerable via soundwaves (normal radio frequency are used)

Display techniques: Volumetric displays

- Products on the market, used in industry (3D cat) and for medical appliances
 - susceptible to puppet theater effect
 - many voxels => high demand on computation power and bandwidth
 - + full motion parallax

The future?

- No mass acceptance of 3D home cinema in the next few years
- Autostereoscopic displays with supermultiview vs electroholographic displays
- Until then: increasing number of 3D systems among early adopters
- 3D content (movies) will be made available

3D vs multiview vs freeview

- Multiview: different videostreams of same motive but from different perspectives
- 3D: special case of multiview
- Freeview: viewpoint selectable

View stream vs video stream

- View stream: a stream containing all images associated with one particular view
- Video stream: contains one or more view streams

Independent compression of view-streams

- Each view stream is encapsulated in its own video stream
 - very inefficient compression
 - + directly compatible to existing systems
 - + errors from one view stream cannot spread to another

Combined video-stream

- Exploit spatial redundancies by predicting the images from one view stream by the images of another view stream

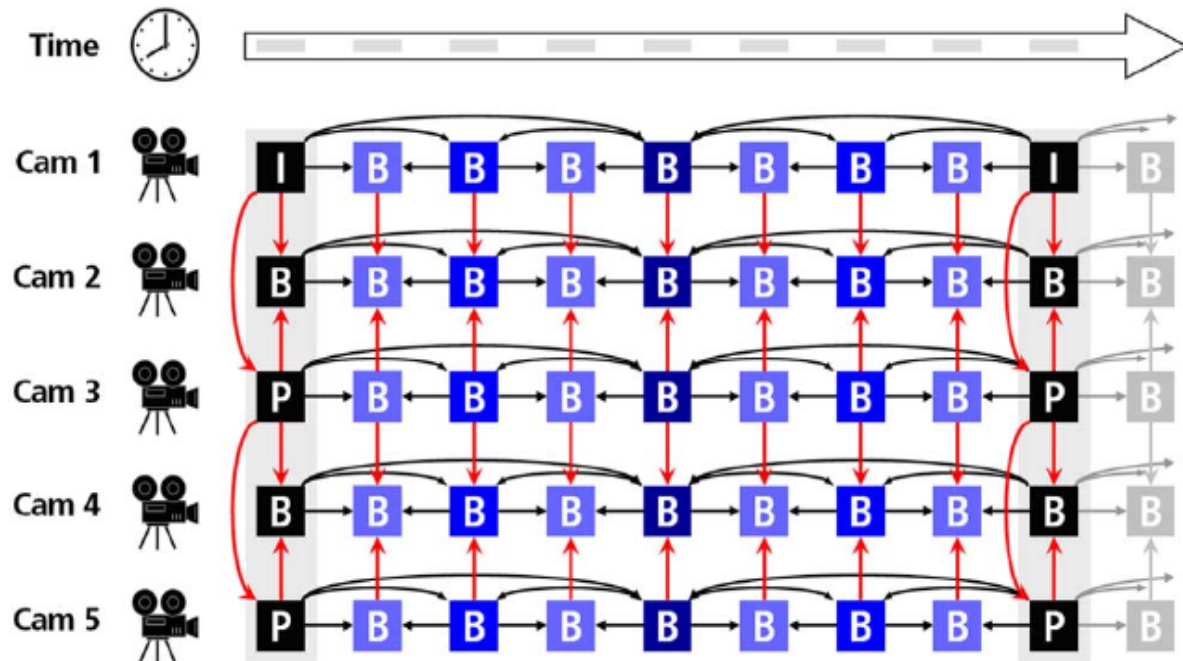

Combined video-stream

- Exploit spatial redundancies by predicting the images from one view stream by the images of another view stream
- Camera normalization might be added for further encoding improvement
- Best proposal (yet) for h.264/MVC
 - very difficult to decode
 - + very good coding performance
 - + compatible to existing solutions

Combined video-stream

- Most of coding gain from obsessive usage of b-frames and interspatial coding of keypictures
- Omit inter-view decoding for non-key pictures?

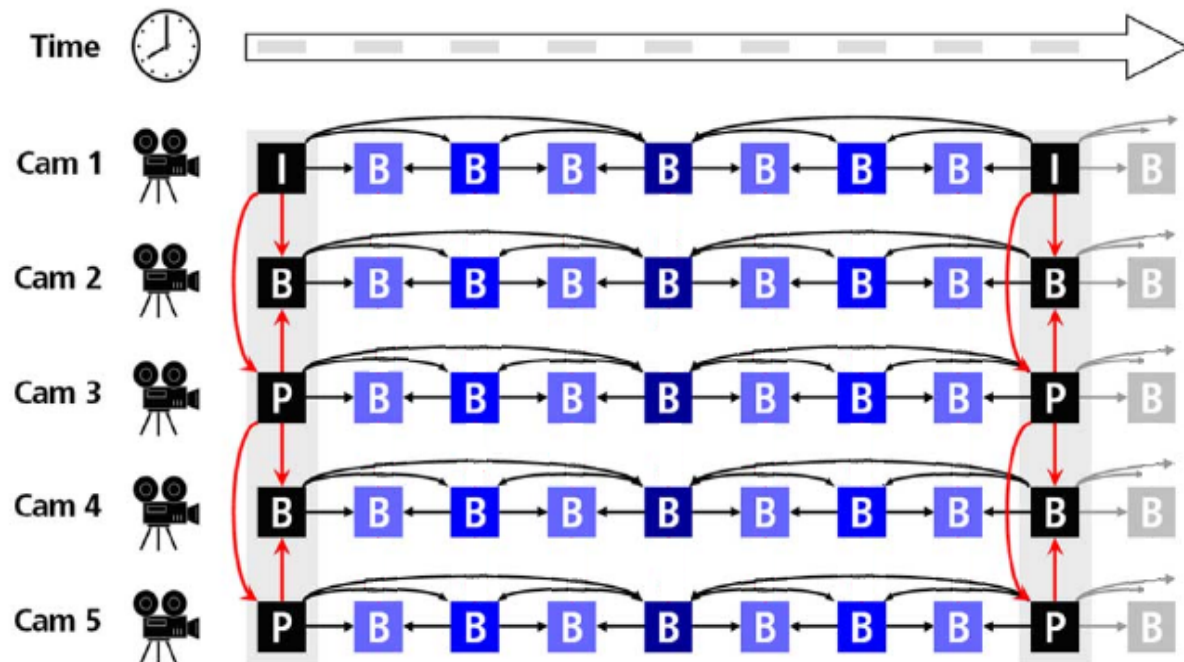

Combined video-stream

- Most of coding gain from obsessive usage of b-frames and interspatial coding of keypictures
- Omit inter-view decoding for non-key pictures?
- Much easier to decode
- Results?

Combined video-stream

- Several displays needs to calculate intermediate views (electroholographic systems, autostereoscopic displays with multiview)
- To be able to do that:
 - Camera parameters (3D-position, angle) have to be transmitted as well
- Other (computational) methods exists as well, but are imprecise and / or computational complex

View-stream & depth stream

- Use only one video stream, add a stream containing depth information



+

=



View-stream & depth stream

- Use only one video stream, add a stream containing depth information
- Typical depth resolution: 1 byte
- Chosen by European ATTEST project
 - problems with occlusion and reflections (though additional stream might be added carrying that information)
 - + very efficient encoding
 - + rendering of different view points easily possible
 - + compatible to existing solutions

View-stream & depth stream

- How to encode depth stream?
- Possible to use a normal video codec (e.g. h.264)
- Prediction from depth image from the normal one (or vice versa)
- Sharing of motion vectors between view stream and depth image possible, too
- But: depth images other properties as normal ones
 - Consisting of large, smooth areas (less important)
 - and sharp edges (more important)
- Depth image coding profits from a variable blocksize

View-stream & depth stream

Flexible Motion Model with Variable Size Blocks for Depth Frames Coding in Colour-Depth Based 3D Video Coding

Tree-growing iterations	Original frame and its partitioning	BPT and the energy of motion compensated frame
0		 $E = 53.39$
1		 $E = 51.77$
2		 $E = 42.37$
3		 $E = 38.02$

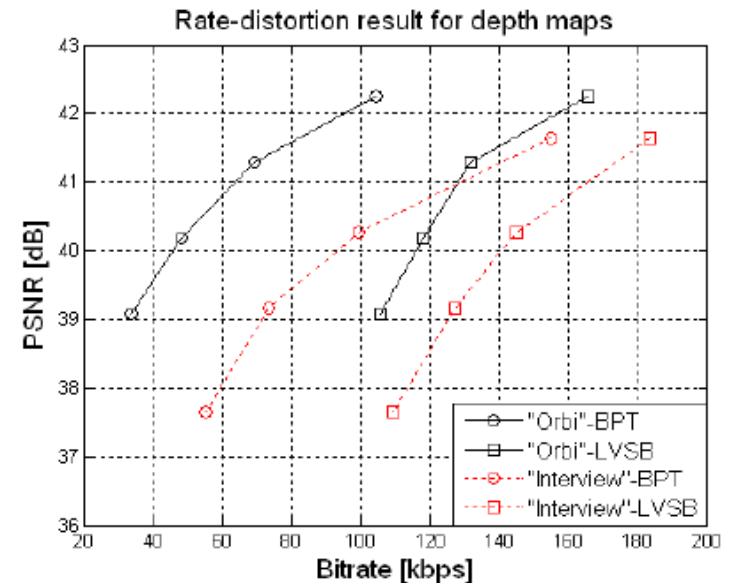

Combined approaches

- Several view-streams and their accompanying depth streams
- Choose which views depending on occlusion in some views (ideally)
- Camera parameters might needed to be transmitted as well
- Results?
 - higher bitrate
 - + suited to deal with different viewpoints and occlusion

Object based approaches

- Object based video coding has been a topic for quiet some time
 - Promises high data-rates
 - Proved to be problematic in practice
- Describe scene as background and several foreground objects
 - + theoretically high data-rates
 - + easy rendering of different viewpoints
 - hard to do in practice

Object based approaches

- Scalable and Efficient Video Coding Using 3-D Modeling
 - Uses depth map to generate a 3D mesh, which is encoded using second-generation wavelets



a

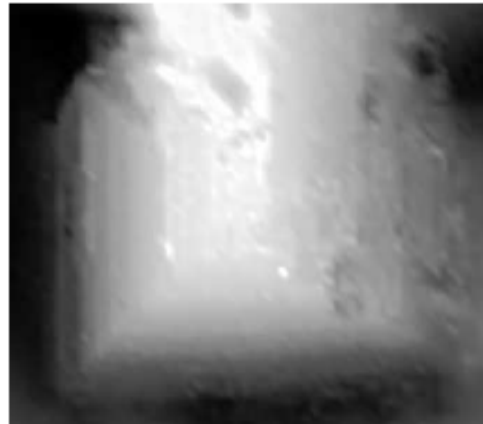

b

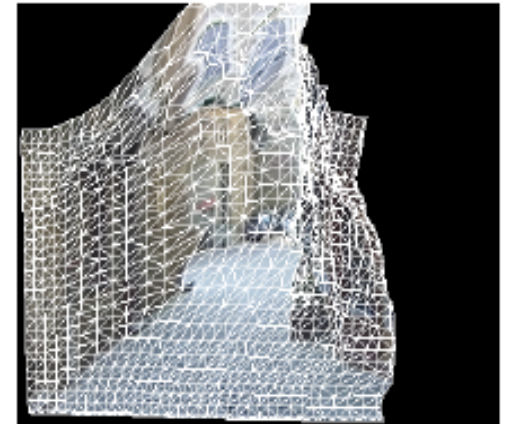

c

Object based approaches

- Scalable and Efficient Video Coding Using 3-D Modeling
 - Uses depth map to generate a 3D mesh, which is encoded using second-generation wavelets
 - Mesh reused for several pictures, updated during transmission
 - Textures are encoded using EBCOT (blockbased coder using wavelets and arithmetic coding) and IPP scheme
 - Camera parameters are transmitted as well
 - Results?

4D Wavelet

- Consider multiview video stream as 4D matrix of pixels
- Encode together using one single 4D wavelet
- But: spatial and temporal redundancy very different
- Practical approaches: do temporal and spatial prediction separately (using different techniques), a final wavelet on the data collected
- Coding performance of the approaches comparable, roughly the same as for the combined video approach
- Computational complexity?

Rendering Issues

- Hole filling
 - If occlusion occurs while rendering an intermediate view (most likely when using view-stream+depthmap)
 - Generally: use depth of the pixel around the hole which is most in the background
 - Use texture of the pixel whose depth was used: but only one color or whole patterns?
 - Possibility to use information of other images in the video stream?

Rendering Issues

- Cross-talk compensation:
 - Add distortion supposed to cancel out “ghosts”

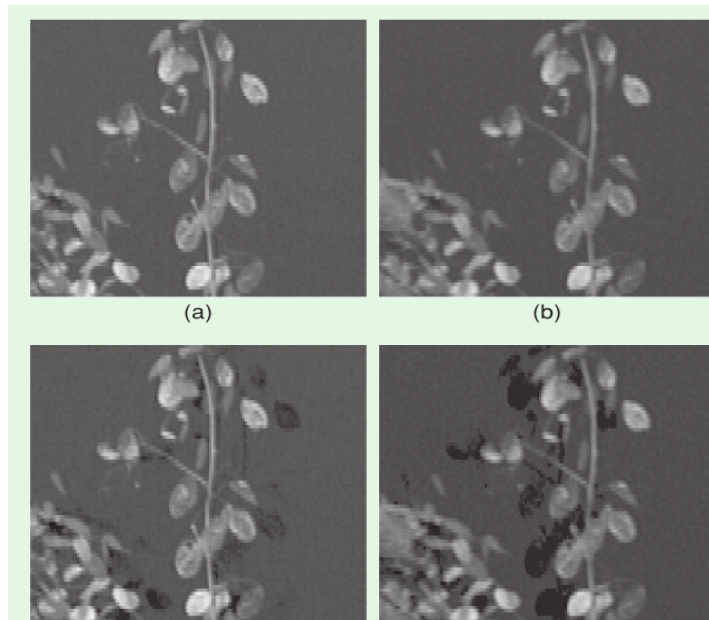

- Need to know display parameters
- Not possible for all ghosts

Rendering Issues

- Rendering for multiview autostereoscopic displays
 - Often: lenticules oriented at small angle

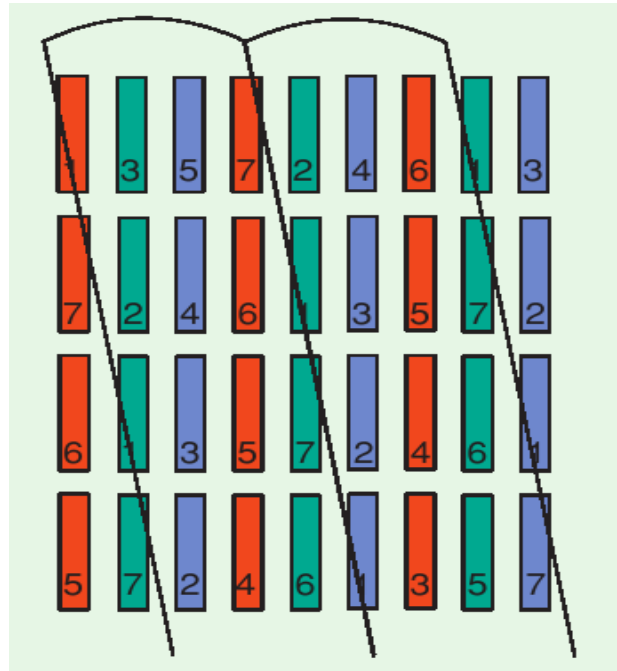

- Reduces picket-fence artifacts
- Balances resolution loss in both directions

Rendering Issues

- Rendering for multiview autostereoscopic displays
 - But how to map the view images to the screen?
 - Approximate by subsampling on a lattice or a union of lattices
 - Alt. approach: approximate in frequency domain
 - Some diodes may get no corresponding pixels
 - Anti-aliasing filter should be added

Rendering Issues

- Rendering for electroholographic displays
 - Need to calculate fringes which determines how to diffract the light
 - Direct computation of fringes too slow for realtime applications
 - Transform 3D scene to holographic plane
 - Generate hogels: small enough to appear to the views as a point, contains color and brightness information
 - Corresponding hogel-vector: contains all information necessary to generate the diffraction necessary for the hogel
 - Combine with precomputed basic fringes to create the physically usable fringes
 - Further compression possible

Rendering Issues

- Rendering for electroholographic displays
 - Example: RIP algorithm (for electroholographic displays)
 - Reconfigurable Image Projection
 - Projects one or more views through a holographic-reconstructed image plane

Thank you very much!

www.icg.isy.liu.se