

Estimation of Orientation and Position of an Accelerometer Mounted to an Industrial Manipulator

Patrik Axelsson, Mikael Norrlöf

Division of Automatic Control

E-mail: axelsson@isy.liu.se, mino@isy.liu.se

18th February 2011

Report no.: LiTH-ISY-R-2995

Submitted to the 50th IEEE Conference on Decision and Control 2011

Address:

Department of Electrical Engineering

Linköpings universitet

SE-581 83 Linköping, Sweden

WWW: <http://www.control.isy.liu.se>

AUTOMATIC CONTROL
REGLERTEKNIK
LINKÖPINGS UNIVERSITET

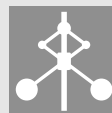

Abstract

A method to find the orientation and position of a three degree-of-freedom (DOF) accelerometer mounted on a six DOF industrial robot is proposed and evaluated on experimental data. The method consists of two consecutive steps, where the first is to estimate the orientation of the sensor using data from static experiments. In the second step the sensor position relative to the robot base is identified using sensor readings when the sensor moves in a circular path and where the sensor orientation is kept constant in a path fixed coordinate system. Once the accelerometer position and orientation are identified it is possible to use the sensor in robot model parameter identification and in advanced control solutions.

Keywords: Robotics, Accelerometer, Estimation

Estimation of Orientation and Position of an Accelerometer Mounted to an Industrial Manipulator

Patrik Axelsson, Mikael Norrlöf

Abstract—A method to find the orientation and position of a three degree-of-freedom (DOF) accelerometer mounted on a six DOF industrial robot is proposed and evaluated on experimental data. The method consists of two consecutive steps, where the first is to estimate the orientation of the sensor using data from static experiments. In the second step the sensor position relative to the robot base is identified using sensor readings when the sensor moves in a circular path and where the sensor orientation is kept constant in a path fixed coordinate system. Once the accelerometer position and orientation are identified it is possible to use the sensor in robot model parameter identification and in advanced control solutions.

I. INTRODUCTION

Current industrial robot development is focused on increasing the robot performance, reducing the robot cost, improving safety, and introducing new functionalities as described in [1]. The need for cost reduction results in the use of cost optimised robot components with increased elasticity and larger individual variations, such as variation of gearbox stiffness or in the kinematic parameters describing the mechanical arm. Cost reduction also implies weight-optimised robots and thus lower mechanical stiffness and more complicated vibration modes. To maintain or improve the robot performance, the motion control must be improved for this new generation of robots. For robots with traditional measurement systems, where only the motor angular position is measured, this can be obtained by improving the model-based control as described in [2]. Another option is to use inertial sensors and observers to improve the estimation of the robot tool position and velocity. To be able to use accelerometers, and get good and reliable results, it is essential that the mounting position as well as the orientation of the sensor are known.

A method to estimate the orientation based on a maneuver in roll, pitch and yaw for the sensor can be found in [3]. Here we propose a method based on six static experiments to find the orientation. We also propose a method to find the mounting position of the accelerometer on the robot, by performing three predefined paths and solving a linear system of equations. The two methods are evaluated on experimental data. It is assumed that the sensor is calibrated by the manufacturer, i.e., each pair of the coordinate axes are orthogonal to each other. If not, a calibration algorithm has to be performed first, see e.g. [4].

All authors are with the Department of Electrical Engineering, Linköping University, SE-58183 Linköping, Sweden {axelsson, mino}@isy.liu.se.

The estimation problem is formulated in Section II. In Section III, the method to find the orientation of the sensor is described, and the method to estimate the mounting position is described in Section IV. The orientation and position estimation is evaluated on experimental data in Section V and Section VI concludes the results.

II. PROBLEM FORMULATION

Assume that the accelerometer is mounted on the robot according to Figure 1(a), where the yellow rectangle represents a tool or a weight, and the black square is the accelerometer. The accelerometer measures the acceleration in a coordinate system $\{a\}$ with unknown orientation where the units are not necessarily m/s^2 . It is desirable to transform the acceleration measure from coordinate system $\{a\}$ to another coordinate system $\{s\}$ with known orientation where the two origins coincide. The units in $\{s\}$ are chosen to be m/s^2 . The orientation of the desired coordinate system can be seen in Figure 1(b). Let ρ_a be a vector in the actual coordinate system $\{a\}$ of the accelerometer and ρ_s a vector in the desired coordinate system $\{s\}$, describing the acceleration in m/s^2 . This means the rotation matrix R from $\{a\}$ to $\{s\}$, the scaling κ between $\{a\}$ and $\{s\}$ and the translation offset ρ_0 ,

$$\rho_s = \kappa R \rho_a + \rho_0, \quad (1)$$

should be computed. When the transformation in (1) has been found the mounting position, i.e., the position of the accelerometer expressed in a body fixed coordinate system attached to the robot, is identified. The basic idea is to move the accelerometer with constant speed in a circular path, perpendicular to the gravity field. The orientation of the accelerometer is kept fixed with respect to the path coordinates during the motion. This means that the acceleration originating from the movement can be isolated from the gravity component, since the acceleration caused by the movement is directed into the center of the circular path. If the desired coordinate system of the accelerometer is rotated such that the gravity is measured along one coordinate axis only, then it is straightforward to obtain the motion acceleration. The measured acceleration is then used together with the theoretical expression of the acceleration to estimate the position.

III. TRANSFORMATION BETWEEN TWO COORDINATE SYSTEMS

A method is proposed to calculate R , κ and ρ_0 in (1). First, a general solution to the problem is derived. Second, the solution will be applied in practice to experimental data.

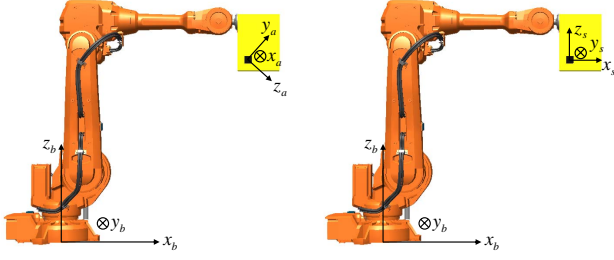

(a) The accelerometer and its actual (b) The accelerometer and the desired coordinate system $\{a\}$. coordinate system $\{s\}$.

Fig. 1. The accelerometer mounted on the robot. The yellow rectangle represents the tool or a weight and the black square on the yellow rectangle is the accelerometer. The base coordinate system $\{b\}$ of the robot is also shown.

The measurements are always affected by noise, therefore define the residual

$$e_k = \rho_{s,k} - \kappa R \rho_{a,k} - \rho_0, \quad (2)$$

where k indicates the sample number, and minimise the sum of the squared norm of the residuals. In other words,

$$\begin{aligned} & \text{minimize} && \sum_{k=1}^N \|e_k\|^2 \\ & \text{subject to} && \det(R) = 1 \\ & && R^T = R^{-1} \end{aligned} \quad (3)$$

where the constrains guarantee that R is an orthonormal matrix. From [5] we have a closed-form solution to this optimisation problem according to

$$\kappa = \sqrt{\frac{\sum_{k=1}^N \|\rho'_{s,k}\|^2}{\sum_{k=1}^N \|\rho'_{a,k}\|^2}}, \quad (4a)$$

$$R = M (M^T M)^{-1/2}, \quad (4b)$$

$$\rho_0 = \bar{\rho}_s - \kappa R \bar{\rho}_a, \quad (4c)$$

where

$$\bar{\rho}_s = \frac{1}{N} \sum_{k=1}^N \rho_{s,k}, \quad (5a)$$

$$\bar{\rho}_a = \frac{1}{N} \sum_{k=1}^N \rho_{a,k}, \quad (5b)$$

are the centroids for the measurements in $\{a\}$ and $\{s\}$.

$$\rho'_{s,i} = \rho_{s,i} - \bar{\rho}_s, \quad (6a)$$

$$\rho'_{a,i} = \rho_{a,i} - \bar{\rho}_a, \quad (6b)$$

denote new coordinates and

$$M = \sum_{k=1}^N \rho'_{s,k} (\rho'_{a,k})^T. \quad (7)$$

N is the total number of measurements. It is assumed that $N \geq 3$ and that all the measurements are non-colinear, i.e., they do not lie on the same line. It is also possible to find a closed-form solution to (1) using unit quaternions, instead of orthonormal matrices, see [6].

To find the transformation from $\{a\}$ to $\{s\}$ the robot moves the accelerometer, i.e., the tool, into N_C different configurations. The gravity vector is measured by the accelerometer in each of the N_C configurations, which gives $N_{M,j}$, $j = 1, \dots, N_C$ measurements for each configuration. Let

$$\{\rho_a\} = \left\{ \{\rho_{a,i}^1\}_{i=1}^{N_{M,1}}, \dots, \{\rho_{a,i}^{N_C}\}_{i=1}^{N_{M,N_C}} \right\} \quad (8)$$

denote the set of all the $N = \sum_{j=1}^{N_C} N_{M,j}$ measurements in all N_C configurations, and let

$$\{\rho_s\} = \left\{ \{\rho_s^1\}_{i=1}^{N_{M,1}}, \dots, \{\rho_s^{N_C}\}_{i=1}^{N_{M,N_C}} \right\} \quad (9)$$

be the theoretical values for the acceleration in the desired coordinate system $\{s\}$ for each configuration, where ρ_s^j , $j = 1, \dots, N_C$ is a constant. The measured accelerations in (8) and the theoretical values in (9) are then used in (4) to (7) to obtain the transformation parameters.

The N_C different configurations can be chosen arbitrary but clever choices make it straightforward to obtain the theoretical values ρ_s^j , $j = 1, \dots, N_C$. Here we suggest six different configurations according to Figure 2, which give

$$\rho_s^1 = (0 \quad 0 \quad g)^T, \quad (10a)$$

$$\rho_s^2 = (0 \quad g \quad 0)^T, \quad (10b)$$

$$\rho_s^3 = (0 \quad 0 \quad -g)^T, \quad (10c)$$

$$\rho_s^4 = (0 \quad -g \quad 0)^T, \quad (10d)$$

$$\rho_s^5 = (-g \quad 0 \quad 0)^T, \quad (10e)$$

$$\rho_s^6 = (g \quad 0 \quad 0)^T, \quad (10f)$$

where $g = 9.81 \text{ m/s}^2$. The sign of g in (10) is opposite the gravity vector in Figure 2. The explanation for this is that an accelerometer measures the normal force which is opposite the gravity vector.

The six configurations in Figure 2 are straightforward to obtain for a six degree of freedom industrial manipulator [7]. The procedure to estimate the transformation parameters is summarised in Algorithm 1.

Algorithm 1 Estimation of the transformation parameters

- 1) Measure the acceleration for the different configurations in Figure 2 to obtain $\{\rho_a\}$ according to (8).
- 2) Construct $\{\rho_s\}$ in (9) from (10).
- 3) Calculate R , κ and ρ_0 from (4) to (7).

It is possible to use other configurations than the one in Figure 2 in Algorithm 1 as long as $M^T M$ has full rank¹.

IV. ESTIMATION OF THE POSITION OF THE ACCELEROMETER

As a second step in the proposed orientation and position estimation process a method is described which can estimate the position r_s of the accelerometer's coordinate system $\{s\}$, expressed in a coordinate system $\{bf\}$ fixed to the robot.

¹The matrix $M^T M$ has always full rank if none of the two sets $\{\rho_a\}$ and $\{\rho_s\}$ are coplanar.

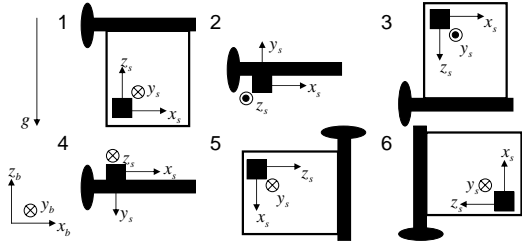

Fig. 2. Six different configurations of the robot tool used in Algorithm 1. The orientation of the desired coordinate system $\{s\}$ is shown for each configuration. The base coordinate system $\{b\}$ and the gravity vector are also shown.

The position estimation uses the basic idea in Section II and it is the position of the desired coordinate system $\{s\}$ that is estimated. It is therefore necessary to first transform the measured acceleration from the actual coordinate system $\{a\}$ to $\{s\}$ according to Algorithm 1.

Start with the derivation of the expression for the acceleration, when the robot is in the configuration shown in Figure 3. The figure shows the vector r_s , the two coordinate systems $\{bf\}$ and $\{s\}$, a world fixed coordinate system $\{b\}$ attached to the base of the robot, a coordinate system $\{w\}$ fixed to the end of the robot arm, a vector $a_s \triangleq \frac{d^2}{dt^2}(r_s)$ describing the acceleration of $\{s\}$, which we want to find an expression for. The figure also shows a parameter θ describing the rotation between $\{bf\}$ and $\{b\}$, two known parameters L_1 and L_2 describing the arm lengths and three unknown parameters l_i , $i = 1, 2, 3$ describing the vector $r_{s/w}$ in $\{w\}$.

All the calculations must be done in the base coordinate system in order to obtain an expression for $\frac{d^2}{dt^2}(r_s)$. It is not possible to do the calculations in, e.g. the body fixed coordinate system $\{bf\}$, because in $\{bf\}$ $\frac{d^2}{dt^2}(r_s) = 0$. The notation $[r_s]_i$ is used to emphasize that r_s is expressed in coordinate system i .

In Figure (3) we see that r_s can be written as a sum of two vectors,

$$[r_s]_{bf} = [r_w]_{bf} + [r_{s/w}]_{bf}, \quad (11)$$

where

$$[r_{s/w}]_{bf} = (l_3 \quad -l_2 \quad -l_1)^T, \quad (12)$$

$$[r_w]_{bf} = (L_1 \quad 0 \quad L_2)^T. \quad (13)$$

The transformation of r_s from $\{bf\}$ to $\{b\}$ can be expressed as

$$[r_s]_b = [Q_{bf/b}]_b ([r_w]_{bf} + [r_{s/w}]_{bf}), \quad (14)$$

where

$$[Q_{bf/b}]_b = \begin{pmatrix} \cos \theta & -\sin \theta & 0 \\ \sin \theta & \cos \theta & 0 \\ 0 & 0 & 1 \end{pmatrix} \quad (15)$$

is the rotation matrix from $\{b\}$ to $\{bf\}$ expressed in $\{b\}$ and $\theta = \theta(t)$ is the angle relating $\{b\}$ and $\{bf\}$ according to Figure 3. Taking the derivative of $[r_s]_b$ with respect to time is

$$\frac{d}{dt}([r_s]_b) = \frac{d}{dt}([Q_{bf/b}]_b) ([r_w]_{bf} + [r_{s/w}]_{bf}). \quad (16)$$

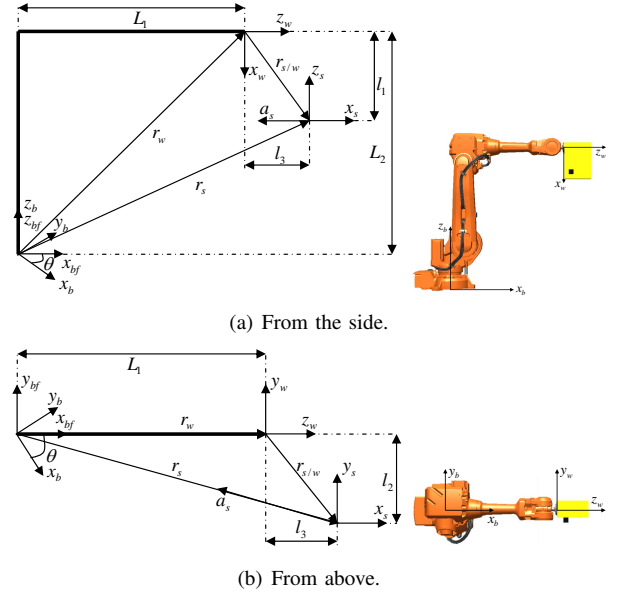

Fig. 3. The first robot configuration for estimation of the mounting position. The black cube on the yellow box indicates the sensor, i.e., the origin of $\{s\}$. The yellow box is attached to the robot in the point $(L_1 \quad 0 \quad L_2)^T$ expressed in $\{bf\}$.

From [8] we have that

$$\frac{d}{dt}([Q_{bf/b}]_b) = S(\omega)[Q_{bf/b}]_b, \quad (17)$$

where $\omega = (0 \quad 0 \quad \dot{\theta})^T$ and

$$S(\omega) = \begin{pmatrix} 0 & -\dot{\theta} & 0 \\ \dot{\theta} & 0 & 0 \\ 0 & 0 & 0 \end{pmatrix} \quad (18)$$

is a skew symmetric matrix. Hence, the time derivative of $[r_s]_b$ can be written

$$\frac{d}{dt}([r_s]_b) = S(\omega)[Q_{bf/b}]_b ([r_w]_{bf} + [r_{s/w}]_{bf}). \quad (19)$$

The second time derivative of $[r_s]_b$ becomes

$$\begin{aligned} [a_s]_b &= \frac{d^2}{dt^2}([r_s]_b) = \frac{d}{dt}(S(\omega)) [Q_{bf/b}]_b ([r_w]_{bf} + [r_{s/w}]_{bf}) \\ &\quad + S(\omega) \frac{d}{dt}([Q_{bf/b}]_b) ([r_w]_{bf} + [r_{s/w}]_{bf}) \\ &= S(\dot{\omega}) [Q_{bf/b}]_b ([r_w]_{bf} + [r_{s/w}]_{bf}) \\ &\quad + S(\omega) S(\omega) [Q_{bf/b}]_b ([r_w]_{bf} + [r_{s/w}]_{bf}) \\ &= S(\omega) S(\omega) [Q_{bf/b}]_b ([r_w]_{bf} + [r_{s/w}]_{bf}), \end{aligned} \quad (20)$$

where $\dot{\omega} = (0 \quad 0 \quad 0)^T$ has been used due to the assumption of constant angular velocity.

It now remains to transform the measured acceleration a_s^M from $\{s\}$ to $\{b\}$. From Figure 3 we see directly that

$$[a_s^M]_{bf} = (a_{s,x}^M \quad a_{s,y}^M \quad 0)^T, \quad (21)$$

hence

$$[a_s^M]_b = [Q_{bf/b}]_b [a_s^M]_{bf}. \quad (22)$$

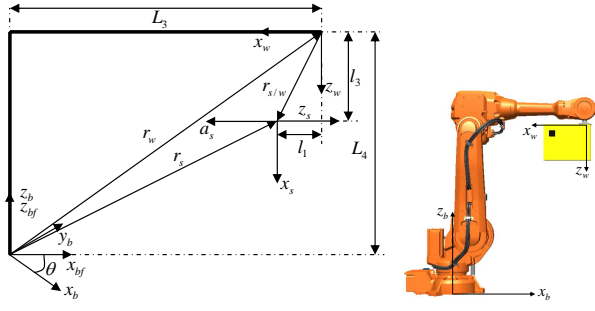

(a) From the side.

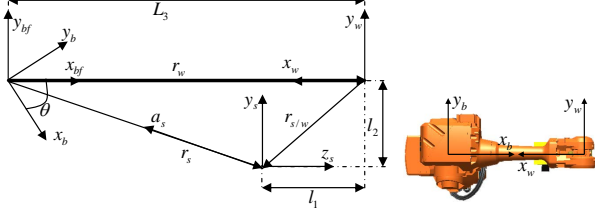

(b) From above.

Fig. 4. The second robot configuration for estimation of the mounting position. The black cube on the yellow box indicates the sensor, i.e., the origin of $\{s\}$. The yellow box is attached to the robot in the point $(L_3 \ 0 \ L_4)^T$ expressed in $\{bf\}$.

Equations (20) and (22) give

$$\begin{aligned} [Q_{bf/b}]_b [a_s^M]_{bf} &= S(\omega)S(\omega)[Q_{bf/b}]_b ([r_w]_{bf} + [r_{s/w}]_{bf}) \\ &\Leftrightarrow \\ [a_s^M]_{bf} &= [Q_{bf/b}]_b^T S(\omega)S(\omega)[Q_{bf/b}]_b ([r_w]_{bf} + [r_{s/w}]_{bf}) \end{aligned} \quad (23)$$

since $[Q_{bf/b}]_b^T = [Q_{bf/b}]_b^{-1}$. Carrying out the matrix multiplication in the right hand side expression of (23) gives

$$[a_s^M]_{bf} = \begin{pmatrix} -\dot{\theta}^2(L_1 + l_3) \\ \dot{\theta}^2 l_2 \\ 0 \end{pmatrix}, \quad (24)$$

where (12), (13), (15) and (18) have been used. Equations (21) and (24) can now be written as a system of equations where l_2 and l_3 are unknown,

$$\begin{pmatrix} 0 & -\dot{\theta}^2 \\ \dot{\theta}^2 & 0 \end{pmatrix} \begin{pmatrix} l_2 \\ l_3 \end{pmatrix} = \begin{pmatrix} a_{s,x}^M + \dot{\theta}^2 L_1 \\ a_{s,y}^M \end{pmatrix} \quad (25)$$

It is thus possible to find l_2 and l_3 from (25) but unfortunately not l_1 . To find l_1 , rotate the sensor according to Figure 4 and do the same kind of movement. The same calculations as before with

$$[r_{s/w}]_{bf} = (-l_1 \ -l_2 \ -l_3)^T, \quad (26)$$

$$[r_w]_{bf} = (L_3 \ 0 \ L_4)^T, \quad (27)$$

$$[a_s^M]_{bf} = (a_{s,z}^M \ a_{s,y}^M \ 0)^T, \quad (28)$$

see Figure 4, give

$$\begin{pmatrix} \dot{\theta}^2 & 0 \\ 0 & \dot{\theta}^2 \end{pmatrix} \begin{pmatrix} l_1 \\ l_2 \end{pmatrix} = \begin{pmatrix} a_{s,z}^M + \dot{\theta}^2 L_3 \\ a_{s,y}^M \end{pmatrix}. \quad (29)$$

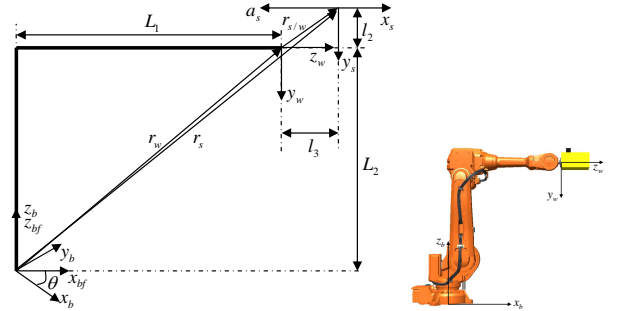

(a) From the side.

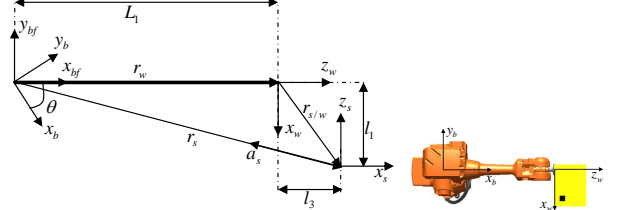

(b) From above.

Fig. 5. The third robot configuration for estimation of the mounting position. The black cube on the yellow box indicates the sensor, i.e., the origin of $\{s\}$. The yellow box is attached to the robot in the point $(L_1 \ 0 \ L_2)^T$ expressed in $\{bf\}$.

Equations (25) and (29) can now be used to estimate the unknown parameters. The estimation of l_i , $i = 1, 2, 3$ will be more accurate if more data are used with different configurations. Therefore, one more robot configuration is used according to Figure 5, which gives

$$[r_{s/w}]_{bf} = (l_3 \ -l_1 \ l_2)^T, \quad (30)$$

$$[r_w]_{bf} = (L_1 \ 0 \ L_2)^T, \quad (31)$$

$$[a_s^M]_{bf} = (a_{s,x}^M \ a_{s,z}^M \ 0)^T. \quad (32)$$

From (23) we now get

$$\begin{pmatrix} 0 & -\dot{\theta}^2 \\ \dot{\theta}^2 & 0 \end{pmatrix} \begin{pmatrix} l_1 \\ l_3 \end{pmatrix} = \begin{pmatrix} a_{s,x}^M + \dot{\theta}^2 L_1 \\ a_{s,z}^M \end{pmatrix}. \quad (33)$$

Equations (25), (29) and (33) can now be written as one system of equations according to

$$\underbrace{\begin{pmatrix} 0 & 0 & -\dot{\theta}_{c1}^2 \\ 0 & \dot{\theta}_{c1}^2 & 0 \\ \dot{\theta}_{c2}^2 & 0 & 0 \\ 0 & \dot{\theta}_{c2}^2 & 0 \\ 0 & 0 & -\dot{\theta}_{c3}^2 \\ \dot{\theta}_{c3}^2 & 0 & 0 \end{pmatrix}}_A \underbrace{\begin{pmatrix} l_1 \\ l_2 \\ l_3 \end{pmatrix}}_l = \underbrace{\begin{pmatrix} a_{s,x,c1}^M + \dot{\theta}_{c1}^2 L_1 \\ a_{s,y,c1}^M \\ a_{s,z,c2}^M + \dot{\theta}_{c2}^2 L_3 \\ a_{s,y,c2}^M \\ a_{s,x,c3}^M + \dot{\theta}_{c3}^2 L_1 \\ a_{s,z,c3}^M \end{pmatrix}}_b, \quad (34)$$

where index ci , $i = 1, 2, 3$ indicates from which robot configuration the measurements come from. Equation (34) has more rows than unknowns, hence the solution to (34) is

$$l = (A^T A)^{-1} A^T b. \quad (35)$$

There exist better numerical solutions to (34) than (35), e.g. $l = A \setminus b$ in MATLAB. The procedure to estimate the position of the accelerometer is summarised in Algorithm 2.

Algorithm 2 Estimation of the mounting position

- 1) Measure the acceleration of the tool $[a_s^M]_s$ and the angular velocity $\dot{\theta}$ for the three different configurations in Figures 3, 4 and 5 when θ varies from θ_{min} to θ_{max} with constant angular velocity.
- 2) Construct A and b in (34).
- 3) Solve (34) with respect to l , for example according to (35).

V. EXPERIMENTAL RESULTS

In this section the proposed orientation and position estimation method described in the two algorithms in Sections III and IV is evaluated using experimental data. For Algorithm 1, the data, i.e., the acceleration values, are collected during 4s for each one of the six configurations in Figure 2 using a sample rate of 2kHz. For Algorithm 2, the arm angular velocity for joint 1 and the acceleration measurements are collected when the robot is in the three different configurations according to Figures 3, 4 and 5. The arm angular velocity for joint 1 cannot be measured, instead, the motor angular velocity $\dot{\theta}_m$ for joint 1 is measured. The arm angular velocity can then be obtained from

$$\dot{\theta}_m = \tau \dot{\theta}, \quad (36)$$

where τ is the gear ratio. In the position estimation experiments data are collected during 4s in each one of the three configurations, but it is only the constant angular velocity part of the data that is used. The same sample rate as before is used, i.e., 2kHz. The accelerometer used in the experiments is a 3-axis accelerometer from Crossbow Technology, with a range of $\pm 2g$, and a sensitivity of 1V/g. The accelerometer is connected to the measurement system of the robot, and hence the acceleration and motor angular velocity can be synchronised and measured with the same sampling rate.

Five tests with different mounting positions and different orientations of the accelerometer have been used for evaluation of Algorithms 1 and 2. The true physical position and orientation of the sensor, see Table I, was measured using a tape measure and a protractor, see Figure 6 where the orientation of the desired coordinate system also is shown. The position was always measured to the center of the accelerometer, since the position of the origin of the accelerometer's coordinate system inside the sensor is unspecified. Note the minus sign for l_2 in test 5 which comes from the fact that the sensor is placed on the other side of the weight than was used in the derivation in Section IV.

Algorithm 1 was applied to the five test cases presented above and the result can be seen in Table II. From Figure 6

TABLE I
MEASURED POSITIONS OF THE ACCELEROMETER IN THE COORDINATE SYSTEM $\{w\}$, I.E., MEASUREMENTS OF l , FOR FIVE DIFFERENT MOUNTING POSITIONS.

Test	Measured position (l) [cm]
1	$(35 \ 4 \ 16.5)^T$
2	$(14.5 \ 7 \ 15)^T$
3	$(38 \ 4 \ 23)^T$
4	$(27 \ 0 \ 5.5)^T$
5	$(35.5 \ -4 \ 15.5)^T$

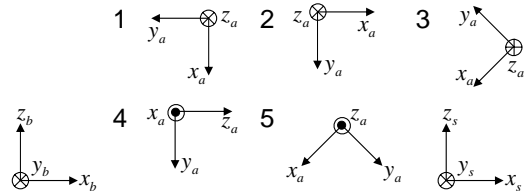

Fig. 6. Orientation for the five mounting positions that were used to evaluate the two algorithms. The orientation of the base coordinate system and the desired coordinate system are also shown.

we have that the rotation matrix R in (1) should look like

$$R^1 = \begin{pmatrix} 0 & -1 & 0 \\ 0 & 0 & 1 \\ -1 & 0 & 0 \end{pmatrix}, \quad R^2 = \begin{pmatrix} 1 & 0 & 0 \\ 0 & 0 & 1 \\ 0 & -1 & 0 \end{pmatrix}$$

$$R^3 = \begin{pmatrix} -a^3 & -b^3 & 0 \\ 0 & 0 & 1 \\ -c^3 & d^3 & 0 \end{pmatrix}, \quad R^4 = \begin{pmatrix} 0 & 0 & 1 \\ -1 & 0 & 0 \\ 0 & -1 & 0 \end{pmatrix}$$

$$R^5 = \begin{pmatrix} -a^5 & b^5 & 0 \\ 0 & 0 & 1 \\ -c^5 & -d^5 & 0 \end{pmatrix},$$

where a , b , c and d are positive numbers that should be close to $\cos(45^\circ) \approx 0.7071$. The superscript indicates the test number. A comparison between these matrices and the rightmost column in Table II confirm that Algorithm 1 performs well. It is more difficult to obtain true values for the parameters κ and r_0 . Figure 7 shows the measured acceleration before and after the transformation for test 1 in configuration 1 (see Figure 2). We see that the transformed signal is 0 in x and y direction and close to 9.81 in the z direction which is expected. All the other test cases and configurations show the same behavior.

Algorithm 2 was also applied for the five test cases in Figure 6 and Table I. Figure 8 shows how the measured data, i.e., the acceleration in $\{s\}$ and the arm angular velocity, can look like when the robot is in the configuration according to Figure 3. Note that it is only the sequence where the angular velocity is constant, in this case around 3 rad/s, that is used. From Figure 3 we see that the acceleration in the z -direction only originate from the gravity which is verified by Figure 8(a). We also see that the acceleration due to the circular motion should be in the negative x -direction and in the positive y -direction which is the case in Figure 8(a). Hence, the transformation from $\{a\}$ to $\{s\}$ is correct here as well.

TABLE II
ESTIMATED PARAMETERS IN (1) USING ALGORITHM 1 FOR FIVE
DIFFERENT TEST CASES.

Test	κ	ρ_0	R
1	9.91	$\begin{pmatrix} 25.05 \\ -23.75 \\ 24.26 \end{pmatrix}$	$\begin{pmatrix} -0.0138 & -0.9998 & -0.0170 \\ -0.0094 & -0.0169 & 0.9998 \\ -0.9999 & 0.0140 & -0.0092 \end{pmatrix}$
2	9.91	$\begin{pmatrix} -23.89 \\ -24.03 \\ 25.11 \end{pmatrix}$	$\begin{pmatrix} 0.9999 & -0.0070 & -0.0131 \\ 0.0129 & -0.276 & 0.9995 \\ -0.0073 & -0.9996 & -0.0275 \end{pmatrix}$
3	9.91	$\begin{pmatrix} 34.80 \\ -23.73 \\ 3.07 \end{pmatrix}$	$\begin{pmatrix} -0.6348 & -0.7724 & -0.0208 \\ -0.0027 & -0.0247 & 0.9997 \\ -0.7727 & 0.6347 & 0.0135 \end{pmatrix}$
4	9.91	$\begin{pmatrix} -24.46 \\ 24.86 \\ 23.74 \end{pmatrix}$	$\begin{pmatrix} 0.0169 & -0.0139 & 0.9998 \\ -0.9992 & -0.0355 & 0.0164 \\ 0.0353 & -0.9993 & -0.0145 \end{pmatrix}$
5	9.92	$\begin{pmatrix} -3.91 \\ 24.95 \\ 33.81 \end{pmatrix}$	$\begin{pmatrix} -0.6314 & 0.7751 & 0.0209 \\ -0.0269 & 0.0050 & -0.9996 \\ -0.7750 & -0.6318 & 0.0177 \end{pmatrix}$

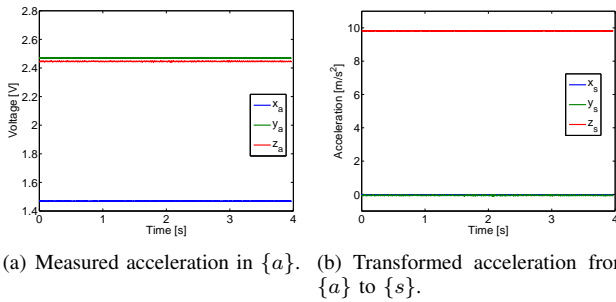

Fig. 7. Measured and transformed acceleration for test case 1 and configuration 1 in Figure 2.

The estimated positions for the five test cases can be seen in Table III. A comparison between the values in Tables I and III gives that the parameters differ at most 2–3 cm for the five experiments. This is considered as acceptable since the estimated position result in a point inside the accelerometer. The actual requirement of the result, in terms of position and orientation accuracy, will depend on the application where the accelerometer is used, for example in estimation as described in [9]. The formulation of the requirement for the accuracy is left as future work.

VI. CONCLUSIONS

A method to find the position and orientation of an accelerometer mounted on a six DOF robot is presented. The

TABLE III

ESTIMATED POSITIONS OF THE ACCELEROMETER IN THE COORDINATE SYSTEM $\{w\}$, I.E., ESTIMATIONS OF l , FOR FIVE DIFFERENT MOUNTING POSITIONS.

Test	Estimated position (l) [cm]
1	$\begin{pmatrix} 35.20 & 6.27 & 15.50 \end{pmatrix}^T$
2	$\begin{pmatrix} 14.20 & 5.82 & 16.85 \end{pmatrix}^T$
3	$\begin{pmatrix} 36.33 & 6.29 & 21.38 \end{pmatrix}^T$
4	$\begin{pmatrix} 29.19 & 1.60 & 5.86 \end{pmatrix}^T$
5	$\begin{pmatrix} 34.75 & -3.91 & 16.50 \end{pmatrix}^T$

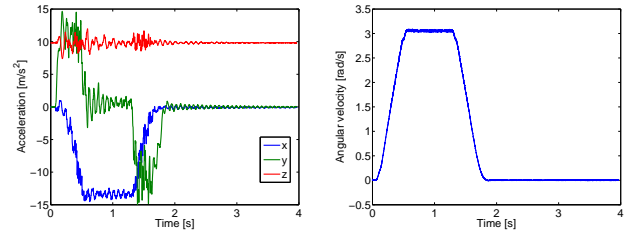

Fig. 8. Measured data, to be used to estimate the position l , for test 1 when the robot is in the configuration according to Figure 3.

method is divided into two main steps, where in the first step, the orientation is estimated by finding the transformation from the actual coordinate system of the accelerometer, with unknown orientation, to a new coordinate system with known orientation. It is also possible to find the scaling parameter from, for example volt, to the acceleration expressed in m/s^2 . The estimation of the orientation is based on static measurements of the gravity vector when the accelerometer is placed in different configurations using the six DOF robot arm. In the second step of the method, the mounting position of the accelerometer in a robot fixed coordinate system is computed using several experiments where the robot is moving with constant speed. Finally, the method is evaluated on experimental data.

ACKNOWLEDGMENTS

This work was supported by the Swedish Research Council under the Linnaeus Center CADICS and by Vinnova Excellence Center LINK-SIC.

REFERENCES

- [1] T. Brogårdh, "Present and future robot control development—an industrial perspective," *Annual Reviews in Control*, vol. 31, no. 1, pp. 69–79, 2007.
- [2] M. Björkman, T. Brogårdh, S. Hanssen, S.-E. Lindström, S. Moberg, and M. Norrlöf, "A new concept for motion control of industrial robots," in *Proceedings of 17th IFAC World Congress*, Seoul, Korea, July 2008, pp. 15 714–15 715.
- [3] E. L. Renk, W. Collins, M. Rizzo, F. Lee, and D. S. Bernstein, "Calibrating a triaxial accelerometer-magnetometer—using robotic actuation for sensor reorientation during data collection," *Control Systems Magazine*, vol. 25, no. 6, pp. 86–95, December 2005.
- [4] S. Bonnet, C. Bassompierre, C. Godin, S. Lesecq, and A. Barraud, "Calibration methods for inertial and magnetic sensors," *Sensors and Actuators A: Physical*, vol. 156, no. 2, pp. 302–311, December 2009.
- [5] B. K. P. Horn, H. M. Hilden, and S. Negahdaripour, "Closed-form solution of absolute orientation using orthonormal matrices," *Journal of the Optical Society of America*, vol. 5, no. 7, pp. 1127–1135, July 1988.
- [6] B. K. P. Horn, "Closed-form solution of absolute orientation using unit quaternions," *Journal of the Optical Society of America*, vol. 4, no. 4, pp. 629–642, April 1987.
- [7] L. Sciavicco and B. Siciliano, *Modelling and Control of Robot Manipulators*, 2nd ed. London, UK: Springer, 2000.
- [8] M. W. Spong, S. Hutchinson, and M. Vidyasagar, *Robot Modeling and Control*. John Wiley & Sons, 2005.
- [9] R. Henriksson, M. Norrlöf, S. Moberg, E. Wernholt, and T. B. Schön, "Experimental comparison of observers for tool position estimation of industrial robots," in *Proceedings of 48th IEEE Conference on Decision and Control*, Shanghai, China, December 2009, pp. 8065–8070.

	Avdelning, Institution Division, Department Division of Automatic Control Department of Electrical Engineering	Datum Date 2011-02-18
	Språk Language <input type="checkbox"/> Svenska/Swedish <input checked="" type="checkbox"/> Engelska/English <input type="checkbox"/> _____	Rapporttyp Report category <input type="checkbox"/> Licentiatavhandling <input type="checkbox"/> Examensarbete <input type="checkbox"/> C-uppsats <input type="checkbox"/> D-uppsats <input checked="" type="checkbox"/> Övrig rapport <input type="checkbox"/> _____
URL för elektronisk version http://www.control.isy.liu.se		LiTH-ISY-R-2995
Titel Estimation of Orientation and Position of an Accelerometer Mounted to an Industrial Manipulator Title		
Författare Patrik Axelsson, Mikael Norrlöf Author		
Sammanfattning Abstract <p>A method to find the orientation and position of a three degree-of-freedom (DOF) accelerometer mounted on a six DOF industrial robot is proposed and evaluated on experimental data. The method consists of two consecutive steps, where the first is to estimate the orientation of the sensor using data from static experiments. In the second step the sensor position relative to the robot base is identified using sensor readings when the sensor moves in a circular path and where the sensor orientation is kept constant in a path fixed coordinate system. Once the accelerometer position and orientation are identified it is possible to use the sensor in robot model parameter identification and in advanced control solutions.</p>		
Nyckelord Keywords Robotics, Accelerometer, Estimation		